

SPECIFICATIONS

SINGLE STROKE, AIR RETURN

Ratio	Lubricant Output (Cu. In.)	Reservoir Capacity	Air Inlet	Lubricant Outlet	Lubricant Operating Pressure (P.S.I.)			
					Type of System	Minimum	Maximum	Recommended
20:1	2.4*	4-1/2 pints	1/4" N.P.T. Female	1/4" N.P.T. Female	SL-42	750	1,000	850
					SL-43	with 40 P.S.I. Air	with 50 P.S.I. Air	with 45 P.S.I. Air
					SL-32	1,200	3,500	1,500
					with 60 P.S.I. Air	with 175 P.S.I. Air	with 75 P.S.I. Air	
					SL-33	1,850	3,500	2,500
					SL-1	with 95 P.S.I. Air	with 175 P.S.I. Air	with 125 P.S.I. Air

*Based on lubricants that are free of entrapped air. Lubricants that are aerated will reduce output of pump.

The 82570 Pump is used as the pumping unit for a centralized lubrication system having a single line circuit of SL-1, SL-32, SL-33, SL-42 and/or SL-43 Injectors dispensing oil.

It is an air operated, single stroke pump requiring air for both forward and return stroke that discharges *2.4 cu. in. of lubricant into the circuit for each pump stroke (Lubrication Cycle).

The total quantity of lubricant needed for the lubrication cycle of the system must not exceed the amount of lubricant discharged per pump stroke.

TO FILL RESERVOIR

The reservoir can be filled through the filler cap at the top of the reservoir.

A strainer is located at the filler cap to prevent the induction of foreign material into the lubricant reservoir. Inspect strainer before filling reservoir. When necessary, lift strainer out and clean thoroughly

TO PRIME SYSTEM

SUPPLY LINES: After pump reservoir has been filled with recommended lubricant, loosen (do not remove) all plugs in dead ends of the injector manifolds and supply lines. Operate pump until lubricant flows from around threads of any loosened plug. Tighten this plug and continue to operate pump until lubricant flows from around threads of another loosened plug. Repeat this procedure until all supply lines are primed.

FEEDER LINES: Fill each feed line with lubricant before connecting lines to outlet of injectors and bearings. This will prevent having to cycle each injector to fill line between injector and bearing.

INJECTORS: Check each injector for proper operation. Injector stem moves when injector discharges lubricant to bearing. This may require cycling system several times. After checking injectors for operation adjust injector for the volume required for each bearing.

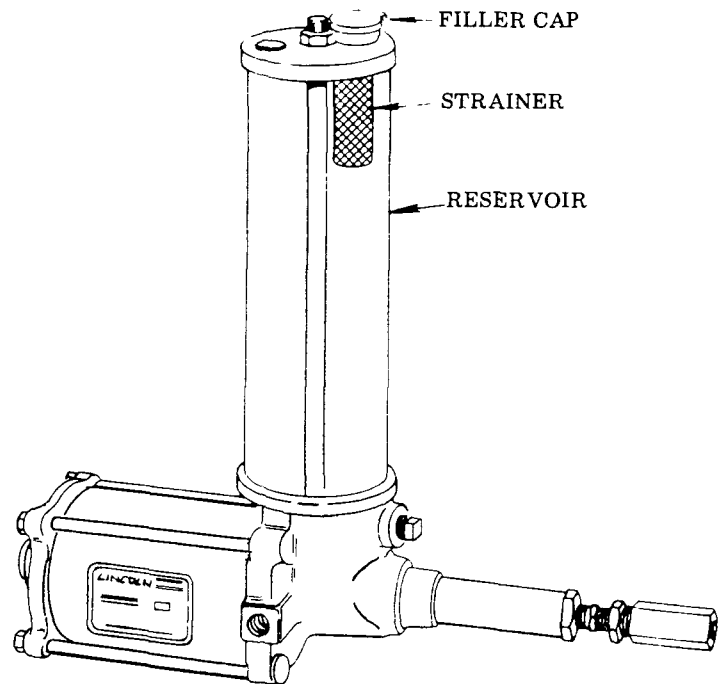

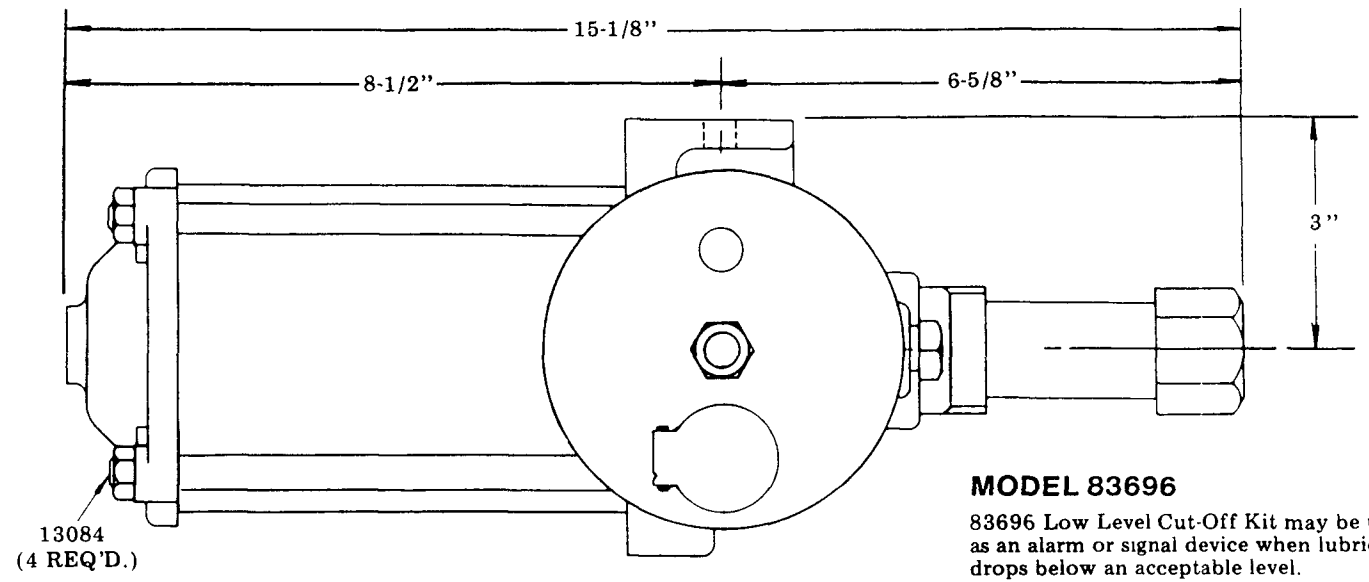

MODEL 83696
 83696 Low Level Cut-Off Kit may be used as an alarm or signal device when lubricant drops below an acceptable level.

**MODEL 82570
 SINGLE STROKE PUMP**

NOTE: TORQUE TO 10 FT. LBS

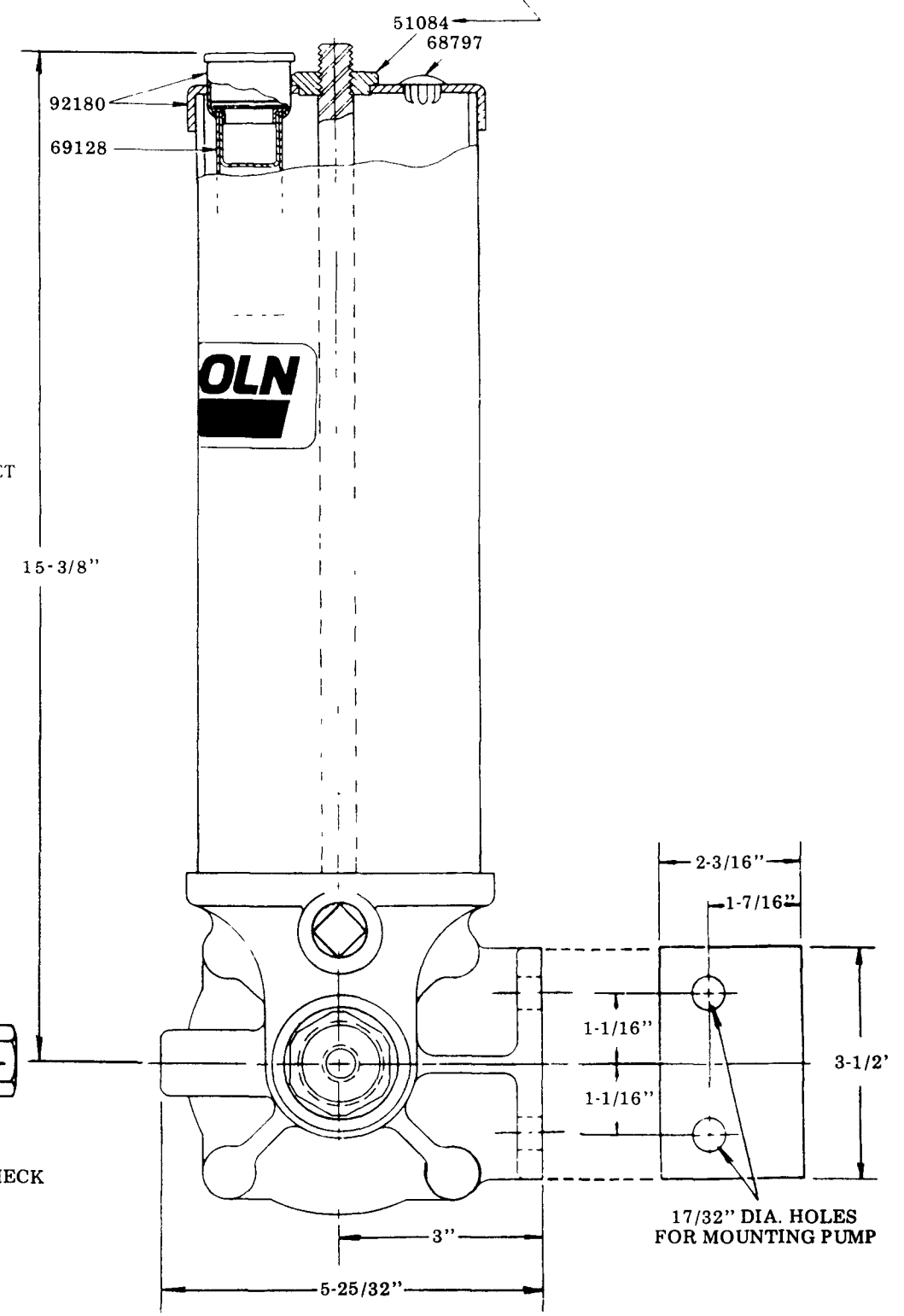

TO CLEAN LINE CHECK 83114
 Remove 91733 Check. Examine packing for presence of foreign particles. If packing is damaged, replace 91733 Check.
 Remove 66250 Ball Check, 55194 Spring and 13649 Ball Stop from 13557 Check Retainer. Examine for presence of foreign particles. Clean thoroughly.

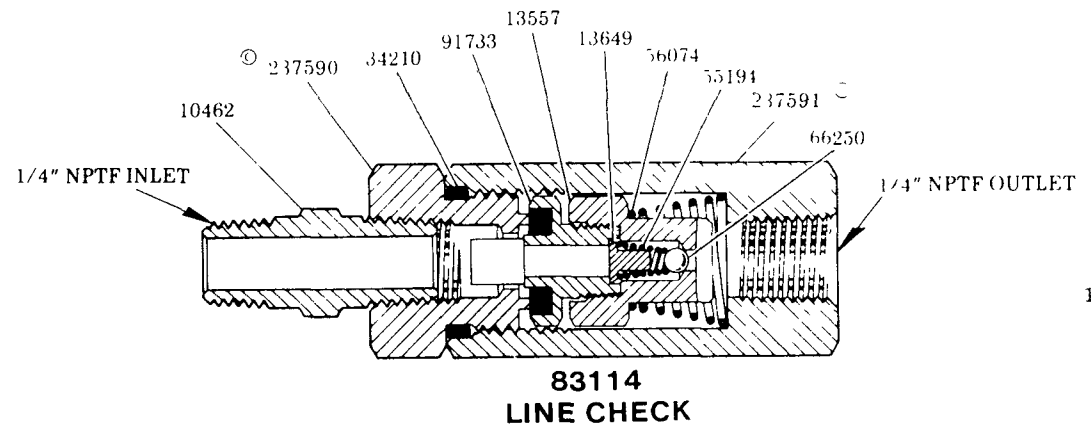

**83114
 LINE CHECK**

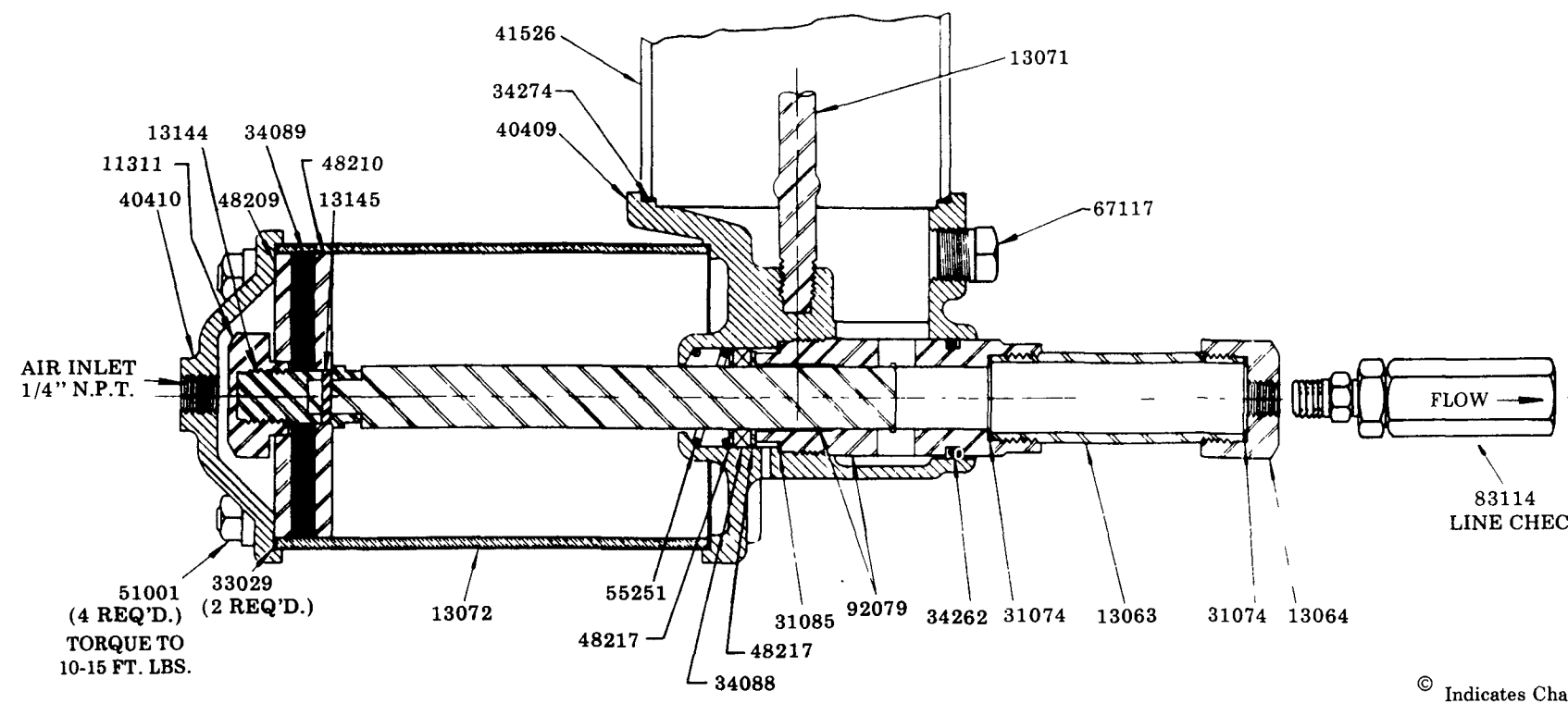

**83114
 LINE CHECK**

© Indicates Change

TYPES OF INSTALLATIONS

Frequency of lubrication cycle can be controlled Manually, Mechanically or Electrically - Pump requires a four-way air valve for operation.

MECHANICAL CONTROL

When using mechanical motion of machine to control lubrication frequency, four-way valve is engaged by cam permitting air to pass through valve to pump forcing air piston forward and lubricant through supply line to injectors. When valve is disengaged, air exhausts back through valve. Air also flows into return side of pump reversing air piston and completing lubrication cycle. Cam Dwell on four-way valves must be arranged for a minimum of 10 seconds.

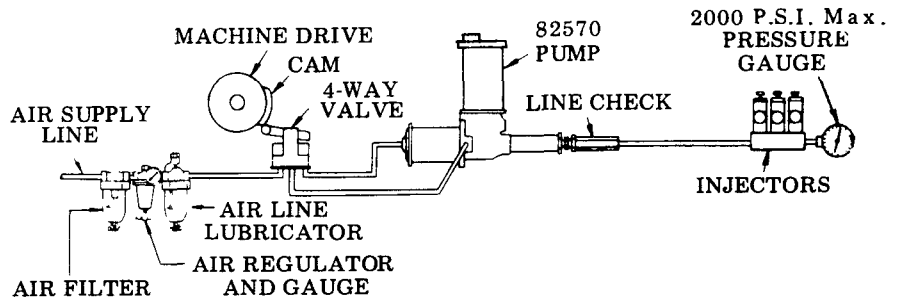

ELECTRICAL CONTROL

Electrical time switch opens four-way valve permitting air to flow to pump forcing air piston forward and lubricant through supply line to injectors. When valve closes, air exhausts back through valve. Air also flows into return side of pump reversing air piston and completing lubrication cycle. Frequency of cycle can be set as desired by adjustable pins in time switch. (See separate instructions for 84101 Program Timer, Section C8, Page 136 Series.)

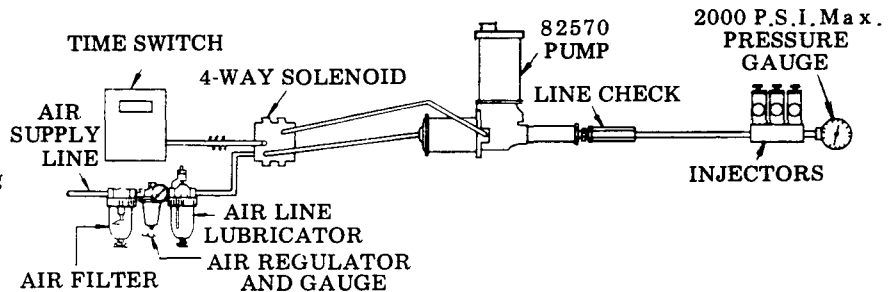

MANUAL CONTROL

Opening four-way valve for a minimum of 10 seconds permits air to flow to pump forcing air piston forward and lubricant through supply line to injectors. When valve is closed, air exhausts back through valve. Air also flows into return side of pump reversing air piston and completing lubrication cycle.

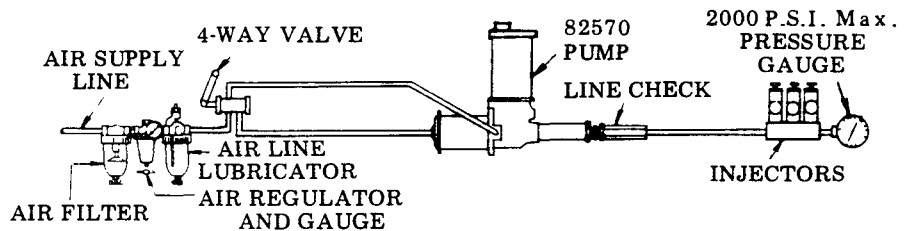

WHAT TO DO IF:

PUMP LOSES PRIME - Check lubricant supply.

SYSTEM FAILS TO CYCLE and calculated system planning has been followed - Lubricant is leaking by packing of 91733 Check or the 66250 Check. Remove and clean. Failure of injectors to cycle can also be caused by a leak in supply lines. Examine supply lines and connections

PUMP FAILS TO OPERATE - Check air supply.

SERVICE PARTS

Part No.	Description	Part No.	Description	Part No.	Description
10462	Nipple	* 31085	Gasket	51084	Nut
11311	Piston nut	* 33029	Gasket	* 55194	Spring
13063	Pump tube	* 34088	Packing	55251	Spring
13064	Outlet	* 34089	Packing	56074	Spring
13071	Tie rod	* 34210	O-ring	* 66250	Steel ball
13072	Air cylinder	* 34262	O-ring	67117	Pipe plug
13084	Tie rod	* 34274	Gasket	68797	Plug button
13144	Packing stud	40409	Body casting	69128	Strainer
13145	Pin	40410	Cylinder cap	83114	Line check assembly
13557	Check retainer	41526	Reservoir	* 91733	Check
13649	Ball stop	48209	Washer	92079	Bushing & plunger
237590	Check seat	48210	Washer	92180	Cover cap
237591	Check body	48217	Washer		
* 31074	Gasket	51001	Nut		

* Recommended service parts inventory.

RETAIN THIS INFORMATION FOR FUTURE REFERENCE

When ordering replacement parts, list: Part Number, Description, Model Number, and Series Letter.

LINCOLN provides a Distributor Network that stocks equipment and replacement parts.